

Testing:

Once connected to the 240V mains supply, the unit must be allowed to charge the battery for at least 24 hours. Conduct the following tests:

- For the first test, the emergency lamp must remain illuminated for at least 2 hours after disconnection from the mains supply.
- Subsequent tests require the unit to illuminate for at least 90 minutes. The results of all tests are required to be recorded in a service logbook, which is to be kept on-site at all times. If the unit fails to remain illuminated for the requisite time, remedial action must be taken to repair the situation and once completed, the unit must pass a subsequent test. For more specific information, please refer to the current edition of the AS 2293.3 Standard.
- Press and hold Test Button or switch Off Mains Supply, check that the emergency lamp is On.
- Release the Test Button or Switch On Mains Supply, check that the emergency is Off (Non-maintained operation)

Trouble Shooting:

Below are a list of common problems and their possible causes.

Fault: The Green LED indicator is not illuminated.

Check: A.C. is connected and is turned on.
Battery is connected.
Test Switch for damage.

Fault: Lamp does not illuminate in emergency mode.

Check: A.C. is connected.
Lamp Head is correctly connected.
Battery is connected

Fault: Lamp illuminates in emergency mode, but only stays on for a short period.

Check: Battery has been allowed to charge for at least 24 hours.
Battery for damage.

Fault: Green LED flashes once every 5 seconds-Battery in disconnected

Check: Battery is connected.

Fault: Green LED blinks off once every 5 seconds- Charging very flat battery

Allow 20min to recover battery then recheck

Fault: Green LED flashes at 2Hz (Fast flash)- Faulty battery

Replace battery

Battery Replacement:

1. Prior to any work, isolate the power to the luminaire that requires battery replacement
2. Open the fitting by following step 2 and 3 from installation section.
3. Remove the Battery Connector from the Emergency Driver.
4. Remove the battery from the EM Driver slot.
5. Place the new Battery in designated clip and reconnect it to the EM Driver
6. Close the batten by following the last two steps from installation instruction.

Caution:

On many building sites, power circuits may be cut off in an uncontrolled and repetitive basis during construction. As a result, any Exit & Emergency Units, on these circuits, will have their batteries discharged or "cycled". The battery in this fitting has been selected to give excellent long-life performance in a controlled AS2293 testing environment. Excessive battery cycling will reduce through-life performance and may lead to premature battery failure. Battery warranty claims, as a result of such abuse, are specifically EXCLUDED from Clevertronics warranty terms.

If flexible wiring is connect to this luminaire and is within arm's reach, the wiring shall be effectively fixed to the wall to reduce the risk of strangulation.



Trade Series 600mm EPIC LED Batten Installation & Maintenance Instruction Leaflet

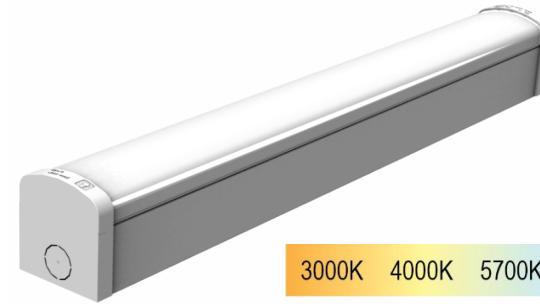

Designed in Australia to comply with the requirements of
AS2293.3: 2005 and AS/NZS CISPR15: 2017

Victoria (Head Office & Manufacturing)

Website: www.clevertronics.com.au

Email: info@clevertronics.com.au

Phone: +61 3 9559 2700

Fax: +61 3 9559 2799

New South Wales

Phone: +61 2 8805 6400

Fax: +61 2 8805 6444

Queensland

Phone: +61 7 3442 9700

Fax: +61 7 3442 9777

South Australia/Northern Territory

Phone: +61 8 8301 8800

Fax: +61 8 8351 8286

Western Australia

Phone: +61 8 9207 0000

Fax: +61 8 9207 0088

New Zealand

Phone: +64 800 548 448

Models: EPIC-600-xx-EM

Options:

Microwave Sensor (HI/LO) xx = SEN

Spare Parts:

1330086-B

LED Driver - 20w Stallion E-MNT

1330087-B

LED Driver - 20w Stallion E-MNT,MS-HL (SEN version only)

ELIFE-X-LI-CKIT-2LED-SL2-NP

EM Driver

1560150

BATT:EcoLith 3.2V 3.0Ah 70mm lead,noBRKT

Important:

It is illegal for anyone, except for a licensed electrician to install or maintain this product. Before installation, ensure that the electricity supply has been switched off and isolated. Installation must be carried out in accordance with the relevant Australian and International Standards.

Warranty:

For Product Warranty information and Terms and Conditions of Sales please refer to our website <http://clevertronics.com.au/terms-conditions-sale-australia-nz/>

Installation:

This product can be mounted to any solid surface. Please follow the below installation steps:

- Refer Images below for the mounting hole and cable access.
- Remove the diffuser by leveraging a flat head screwdriver into the provided slot(A). This is to be done on the end marked "Open this end". Once the endcap is unclipped hinge it away from the diffuser until a click is heard. Undo the diffuser securing screw (B), lift diffuser away from body(C).
- Disconnect the LED strip connector and EM LED connector. If connected unhook the lanyard
- Position the batten in the desired location.
- Mark out the fixing points on the mounting surface.
- Install appropriate fixing hardware.
- Route power supply cables through the access hole as the rear of the fitting or the ends if using surface conduit (punch out the knock-outs in the plastic end caps)
- Fasten the batten to the surface.
- Terminate the supply cable to the terminals marked L_{EM}, N, L_{SW} and E (240V AC/50Hz)
- Set Colour Switch to the desired colour (3000K, 4000K, 5700K)
- Attach the diffuser to lanyard, Re-connect the LED strip connector and EM LED connector..
- Re-install the diffuser, Tighten diffuser screw (B) and close endcap clip (A).

NOTE:

This luminaire (with reinforced insulation between control/LED terminal and AC Supply) contains non-user replaceable light source and battery – to be replaced (if required) by the manufacturer or his service agent or a similar qualified person.

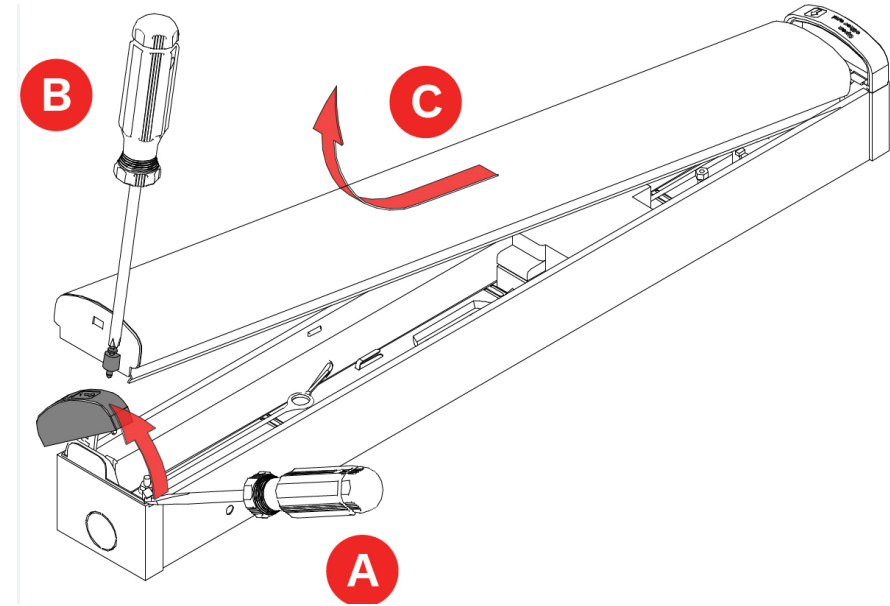

Wiring:

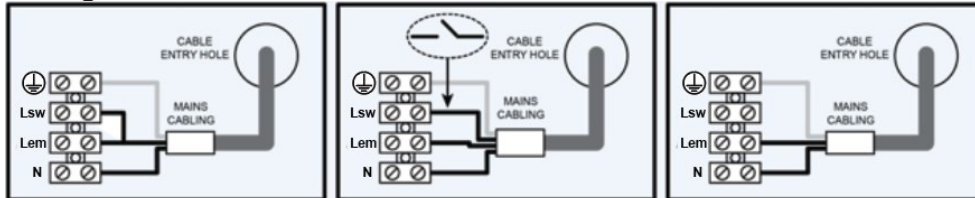

Figure A

Permanently on, 24hr operation. The switched active and un-switched active connections are bridged ensuring the battery charger and general lighting LED driver is permanently energised.

Figure B

Switched operation of the general lighting LED driver. The switched active is wired separately via a switch to provide on/off control of the general lighting. The un-switched active supplying battery charger is permanently energised.

**The switched and un-switched active should originate from the same circuit breaker or RCD.*

Figure C

Non-maintained operation. The switched active is not connected and the general lighting LED driver will be off (permanently). The un-switched active supplying battery charger is permanently energised.

Sensor Version:

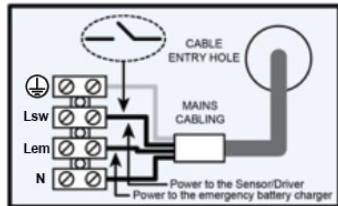

Dimensions:

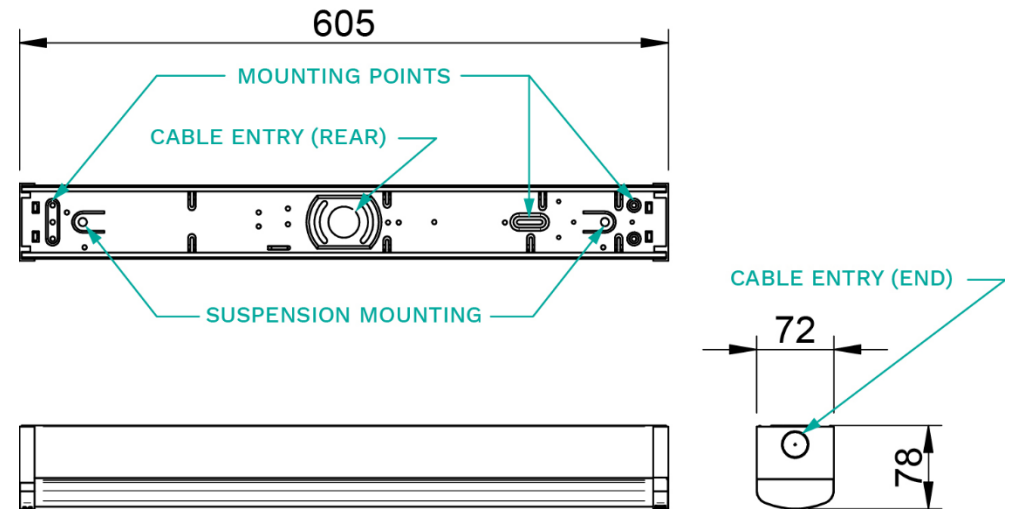

Colour Setting:

